

## SYGEF ECTFE

# Highest reliability under extreme conditions

The piping system for aggressive applications



The SYGEF ECTFE system  
ensures maximum safety.

# Extremely reliable



The SYGEF ECTFE system also performs excellently under extreme conditions, consistently and reliably. Limited maintenance and a long service life ensure considerable cost reductions.

For the transport of aggressive media such as concentrated sulfuric acid ( $\text{H}_2\text{SO}_4$ ) or hydrogen peroxide ( $\text{H}_2\text{O}_2$ ) under high pressure and temperature conditions, alternative materials such as PP, PVC or PVDF quickly reach their limits. At the same time, due to their lengthy assembly times, high weight and exterior corrosion susceptibility, lined steel pipes are not an entirely satisfying system solution either.

In contrast, the ECTFE system from GF Piping Systems was designed specifically as a high-end solution for extreme conditions. The piping system has been proven to be extremely resistant and reliable for the transport of bases or highly concentrated acids. At the same time, users benefit from quick assembly, a long system service life, and lower initial costs than welded PFA systems. The combination with the latest IR welding technology from GF Piping Systems provides the highest level of safety for people, the environment and the production process.

## Content

<b>Extremely reliable</b>	<b>3</b>
<b>Benefits SYGEF ECTFE</b>	<b>4–5</b>
<b>The GF Piping Systems testing laboratory</b>	<b>6</b>
<b>System overview SYGEF ECTFE</b>	<b>7–9</b>
<b>SYGEF ECTFE applied</b>	<b>10–13</b>
<b>Infrared welding</b>	<b>14</b>
<b>Services</b>	<b>15</b>
<b>SYGEF ECTFE Scope of delivery</b>	<b>16–37</b>

# SYGEF meets the highest requirements since 45 years

With the ECTFE system we are expanding the established SYGEF brand family by a safe, reliable and cost reducing high-end solution for extremely aggressive media. SYGEF ECTFE is suitable for exceptionally demanding applications in the industrial sector and combines highest chemical, pressure and temperature resistance with economic and efficient operation.

For nearly 45 years, the SYGEF fluoropolymer systems have been used in industrial applications with high demands for physical properties such as pressure, temperature and chemical resistance, as well as highest purity requirements in the high purity sector. SYGEF systems are known across all industries for the highest requirements in terms of material and manufacturing quality.

With the new SYGEF ECTFE system, GF Piping Systems has expanded its proven solutions with a complete system, which sets new standards for transporting particularly aggressive media such as highly concentrated sulfuric acid. The ECTFE product portfolio includes the complete range of pipes, fitting and innovative jointing technology. This gives users a suitable solution that complements the existing industrial portfolio of PP-, PVC- or PVDF-plastic piping

systems. Similar to all SYGEF system solutions, the particularly robust ECTFE system is produced at the world's largest clean room plant for fluoropolymer products in Ettenheim, Germany. The fully controlled processes coupled with unique quality assurance warranties 100% traceability of each individual product.

The ECTFE fluoropolymer system benefits wherever other plastic piping system solutions reach their limits or metal pipes are chemically attacked. Alternative materials like PFA or PTFE can be quickly, reliably and cost-effectively substituted by ECTFE. Compared to PFA ECTFE enables higher pressure ranges and allows a streamlined and efficient installation design. The ECTFE system is about 50% more cost-effective than IR-welded PFA solutions.



# Safe handling of aggressive media



The SYGEF ECTFE piping system shows its advantages when it comes to manufacturing, transport and filling of concentrated chemicals under high temperature and pressure. This property makes ECTFE an ideal addition to the SYGEF fluoropolymer family. Due to faster assembly, lower initial costs and longer service life compared to alternative solutions, an economical transport of particularly aggressive media is achieved. The system is well suited for the chemical process industry, water treatment and microelectronics.



## + Safe and reliable

The ECTFE system enables safe handling of chemicals including those with a pH value below 2 and above 12. At the same time, the high-end system solution is absolutely reliable thanks to advanced IR welding technologies.

## + Long system lifetime

Aggressive media often considerably affect the service life of piping systems. Due to its extremely high resistance, ECTFE reduces maintenance costs and eliminates process interruptions.

## + 200 % higher pressure range

Due to its excellent mechanical properties, ECTFE allows a 200% higher pressure range than PFA. This provides users with more efficient processes and higher safety standards.

## + 20 % more efficient pipe volume

Thanks to its high mechanical stability, the wall thickness of the ECTFE has optimal SDR and is 20% more efficient compared to PFA. Thereby the system enables higher flow rates with equal or less space requirements.

## + Low initial costs

Compared to the widely used PFA solutions, ECTFE is also characterized by significant cost savings and optimum permeation characteristics. The initial costs are 50% lower than those of IR-welded PFA piping systems.

## + 85 % faster assembly

The ECTFE components are securely connected in a few minutes using most advanced IR-welding technology. Compared to pipes made of lined steel, installation time is significantly reduced.



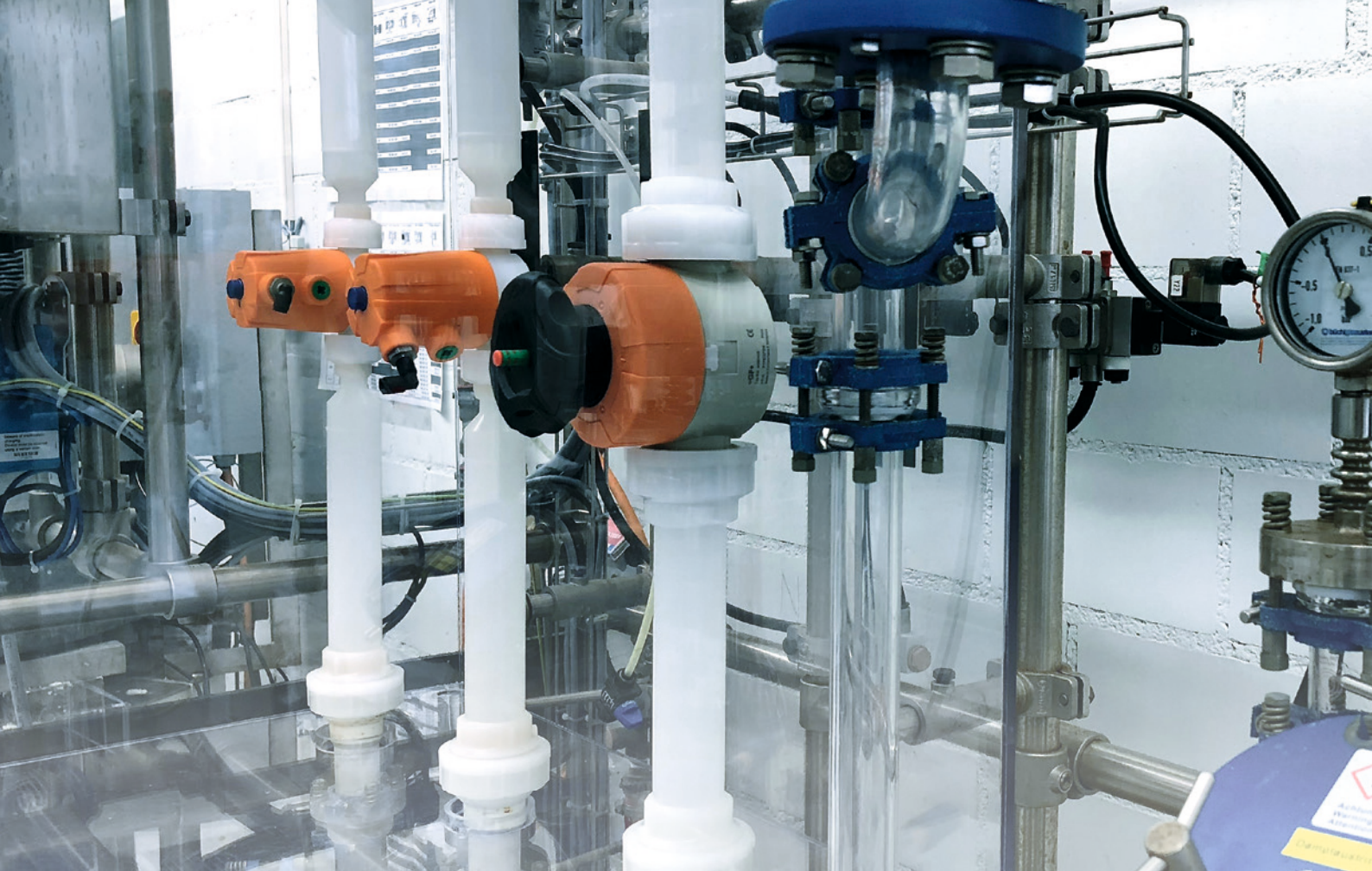

Best quality warranted by accredited test laboratory

# Safe and reliable

From the characteristics of the raw material to the quality control of the finished part: GF Piping Systems ensures that the warranted properties are met thanks to its unique laboratory expertise.

GF Piping Systems examines the material, jointing technology, and products beyond mandatory standards in detail at its accredited laboratory (OSO/IEC 17025) in Schaffhausen (Switzerland). The guaranteed characteristics of the applied ECTFE raw materials are tested by GF Piping Systems. Despite decades of collaboration with material suppliers, GF Piping Systems strictly adheres to the principle of "trust and verify." SYGEF ECTFE has been and is continuously tested under temperature, also with chemicals, under long-term conditions. So you can be assured that information from our

chemical experts is based on decades of experience and various tests. Your medium is tested by GF Piping Systems under application conditions on real components. Additional details are also provided by the microscopic inspection of the parts morphology and the IR-joints. Besides important insights regarding production process and correct fusion parameters, the effect of test and application conditions is also carefully inspected. Has the product been chemically attacked? Extremely experienced staff members examine the samples and products not only visually but also using infrared microscopy.



# Characteristics of SYGEF ECTFE

Overview of SYGEF ECTFE products and system characteristics

## System range

Products	d	20	25	32	40	50	63	75	90	110
	DN	15	20	25	32	40	50	65	80	100
Pipes										
Fittings										
Unions										
Flange rings										
Gaskets										
Valves <sup>2</sup>										
Automation										
Pipe clips										
IR welding machines										

<sup>2</sup> on request

## System properties

### SYGEF ECTFE

Material	ECTFE Halar
Color	opaque
Density	~1.68 g / cm <sup>3</sup>
Thermal expansion coefficient	0.08–0.135 mm / mK (DIN 53752 / ASTM D696)
Thermal conductivity at 23°C	0.15 W / mK (ASTM C177)
Tensile stress at 23°C	≥ 30 N / mm <sup>2</sup> (EN ISO 527-1)
E-module at 23°C	≥ 1 600 N / mm <sup>2</sup> (EN ISO 527-1)
Charpy notched impact strength at 23°C	no breaking (EN ISO 179 / 1eA)
Dimensions	d20–d110 acc. to ISO 10931
Temperature range raw material	–76 °C to 140 °C
Temperature range applied on chemicals	0 °C to +80 °C
Surface properties	Inner surface Ra < 0.5 µm (20 µin) for injection moulded and extruded components
Internal stress	Pipes: ≤ 2.5 N / mm <sup>2</sup> ; stress relieved by thermal annealing during manufacturing
Packaging	Pipes are capped and individually packed in foil like the fittings
Marking and labeling	During production, all components are embossed with a permanent identification to ensure full traceability: - Brand name - Material - Dimensions - Pressure rating - Lot number - Product description - Article number - Standards Colored labels for differentiation between SYGEF ECTFE and SYGEF Standard PVDF

## Chemical resistance

Chemical resistance at 20 °C			Thermoplastics				Steel		
Detailed evaluation is depending on concentration. Contact ChemRes			semi-crystalline		amorphous		SS	SS	Hastelloy C 276
Media group	Medium	Concentration	ECTFE	PVDF	PVC-U	PVC-C	1.4301 / 304	1.4401 / 316	
Acids	<b>Inorganic oxidizing acids</b>								
	Nitric acid	> 50 %	+	+	0	0	+	+	+
	Chromic acid	> 30 %	+	+	0	0	+	+	+
	Sulfuric acid	≥ 96 - 98 %	+	0	+	-	0	0	+
	<b>Inorganic non-oxidizing acids</b>								
	Hydrochloric acid	</= 37 %	+	+	+	+	-	-	0
	Hydrofluoric acid	> 40 %	+	+	-	-	-	-	0
	<b>Organic acids</b>								
Formic acid	> 85 %	+	+	0	-	0	+	+	
Acetic acid	> 85 %	+	+	0	-	0	+	+	
<b>Bases</b>	<b>Inorganic (caustic soda lye)</b>	</= 50 %	+	-	+	0	+	+	+
<b>Halogens</b>	<b>Chlorine, bromine, iodine, (no fluorine)</b>		0	0	0	0	-	-	0
<b>Fuels / oils</b>	<b>Aliphatic hydrocarbons</b>		+	+	0	0	+	+	+
	<b>Aromatic hydrocarbons</b>		+	+	-	-	+	+	+
<b>Oxidizing agent</b>	<b>Hypochlorite, hydrogen peroxide, ...</b>		+	-	+	0	0	0	+

+ resistant  
 0 conditionally resistant, please consult [gss@georgfischer.com](mailto:gss@georgfischer.com)  
 - not resistant

Please note: The above list is only intended as a guideline and does not replace an in-depth review of material suitability for the particular application. The information is based on our experience and is state of the art. This data consists only of general indicators. In practice, however, other factors such as concentration, pressure and jointing technology must also be taken into consideration. The technical data is not binding and does not constitute expressly warranted characteristics of the goods. Please contact [gss@georgfischer.com](mailto:gss@georgfischer.com) for help with selecting the right materials.

## Online tool Chemical resistance

Our teams of experts have decades of experience in the chemical resistance of materials. The online tool ChemRes PLUS provides you with the most important basic information.

The ChemRes PLUS Online Tool from GF Piping Systems summarizes a large amount of data about materials and media and presents it visually. Choose among all materials and solvent components of the GF Piping Systems product portfolio and compare them to get a comprehensive overview.



- Select the medium you want to transport
- Select the pressure/temperature point corresponding to your requirements
- ChemRes PLUS shows you the suitable materials in a clearly arranged table

### More information

[www.gfps.com](http://www.gfps.com)



# Pressure-temperature diagram

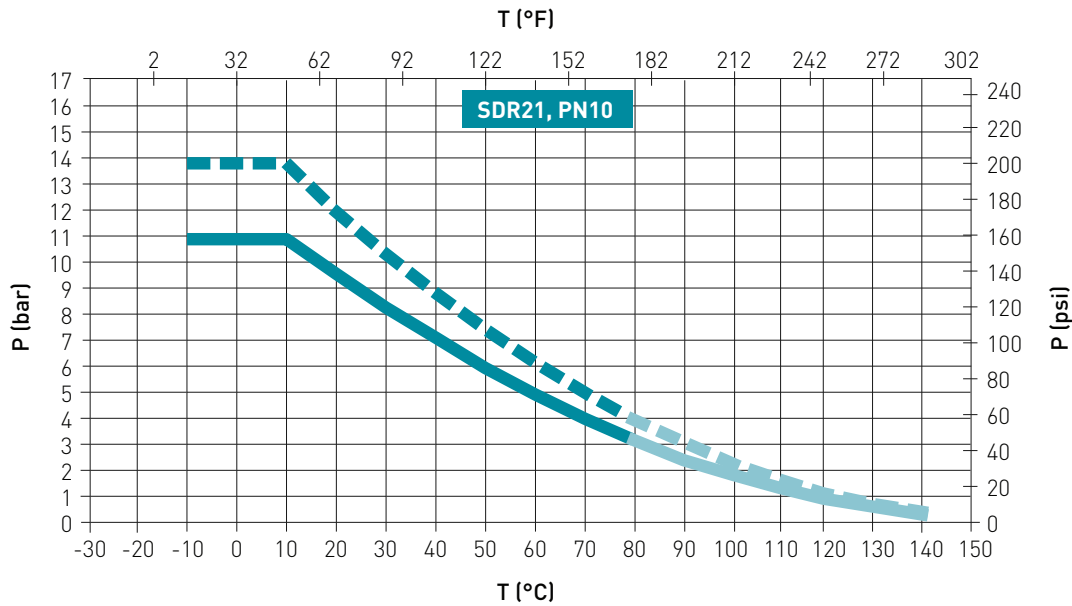

P Permissible pressure in bar, psi

T Temperature in °C (Celsius), °F (Fahrenheit)

--- C = 1.6  
— C = 2.0

GFPS recommends the use of C=2.0 to include the reduction factor of 0.8 for weld joints.

The pressure/ temperature curve based on medium water, operating temperature of 20°C, valid life time of 25 years and the design factor of C = 2.0 or C = 1.6 respectively

More information regarding technical specifications can be found online in our planning fundamentals: [www.gfps.com](http://www.gfps.com)  
For special requests and additional planning support please contact: [gss@georgfischer.com](mailto:gss@georgfischer.com)

## System components



Pipes



Fittings



Valves



Automation



Jointing technology

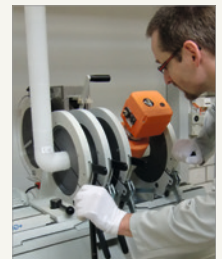

Customizing and training

## Application

# Storage of acid

The transport of aggressive media in particular, such as highly concentrated sulfuric acid, requires an exceptionally reliable piping system to ensure safe handling at all times. The ECTFE assortment is used to fill the tank and subsequently transport such medias. In this case, one of the tanks contains 98 % sulfuric acid, a very corrosive liquid.



# Special features



## Highest safety requirements

Safety is the top priority when handling aggressive media. For this reason, the highest safety requirements must be met at every work step or production process.



## Double protection

For safety reasons, two valves are always used redundantly for applications such as these. This ensures that filling is interrupted even if one of the valves does not close.



## Pneumatic actuators

Electric actuators should be avoided when handling combustible or explosive media. The use of pneumatic actuators adds a maintenance-free and efficient unit to the process.



## Low stress installation

- Lowest stress production
- Stress relieved pipes (annealed)
- Joining technology (IR)
- Design & installation

## Your benefits

- Extreme corrosion resistance and reliability when handling aggressive chemicals
- Great permeation and temperature resistance
- Low initial and maintenance costs
- Long system service life



## Application

# Dosing sodium hypochlorite

The ECTFE range can also be used effectively for drinking water treatment. In the application example, SYGEF ECTFE is used for a dosing system in water treatment. A sodium hypochlorite solution is dosed into water for disinfection and preparation for drinking water use.

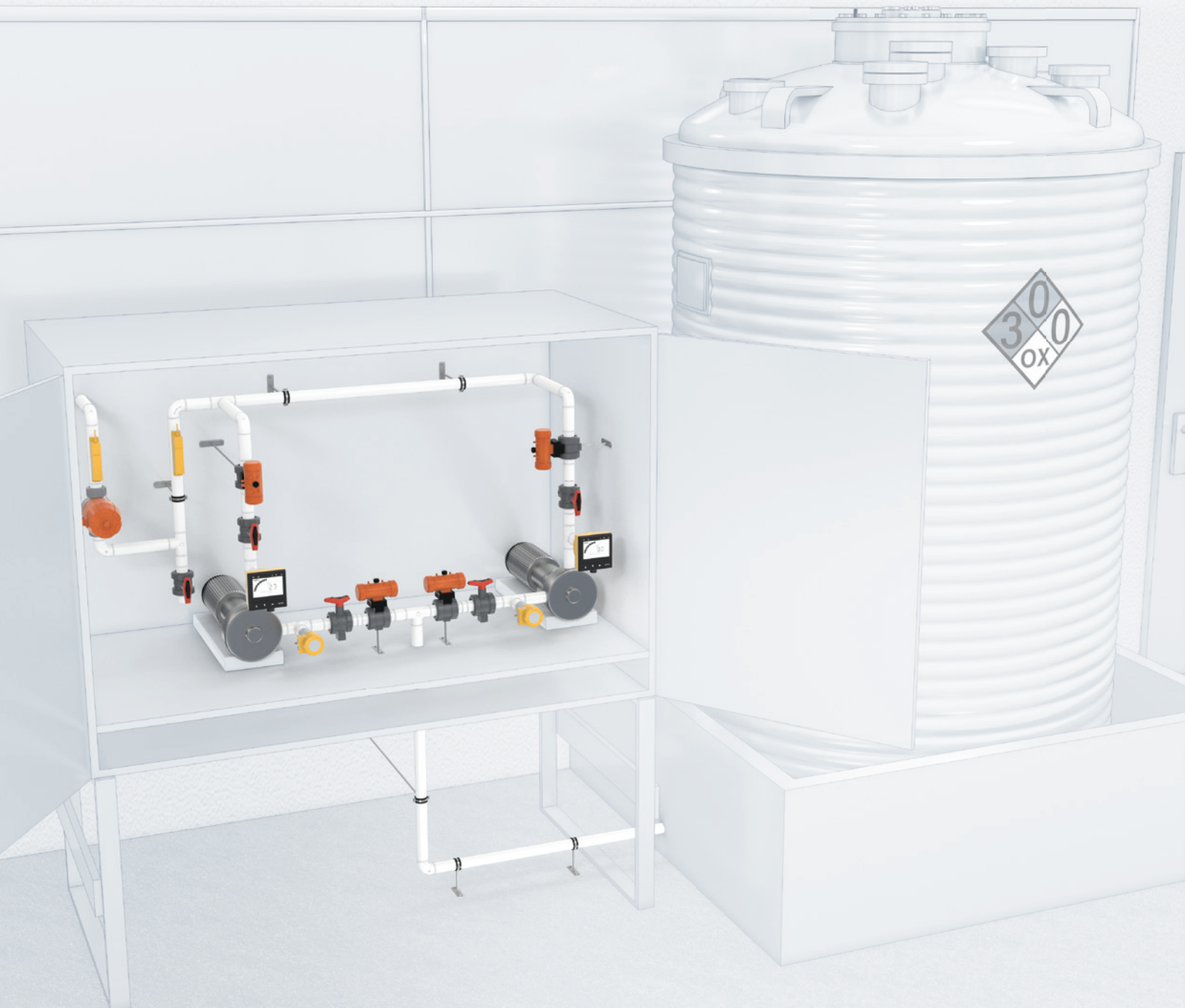

# Special features



## Highest safety requirements

Safety is the top priority when handling aggressive media. For this reason, the highest safety requirements must be met at every work step or production process.

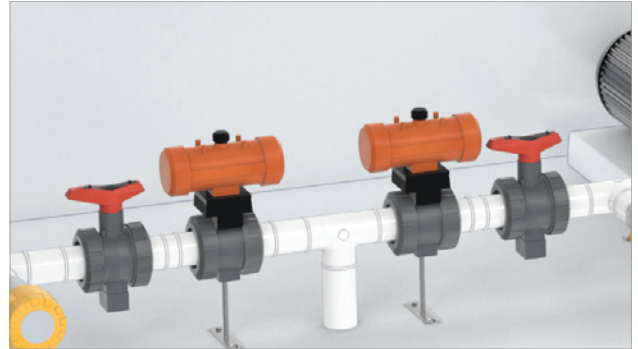

## Double protection

For safety reasons, two valves are always used redundantly for applications such as these. This ensures that filling is interrupted even if one of the valves does not close.



## Ultrasonic Flow Meter

The U1000 V2 is based on non-contact ultrasonic measurement and can be installed without service interruption. It provides precise results, cost-effective operation and supports digital interfaces.



## Offering planning assistance

The experts from GF Piping Systems will provide you with detailed information on materials, chemical resistance, dimensions, jointing technology, installation techniques, approvals and standards.

## Your benefits

- Extreme corrosion resistance and reliability when handling aggressive chemicals
- Great permeation and temperature resistance
- Low initial and maintenance costs
- Long system service life



# Fast and easy installation thanks to infrared

In the area of pressure piping systems for industrial applications there are high requirements for mechanical stability, reproducibility and quality of the jointing technology. The IR-110 A is the new generation of infrared welding machines from GF Piping Systems. With its automation, intuitive handling and system safety, it ensures the highest efficiency for all users.



User-friendly and easy to operate: The IR-110 A

## Advantages of welding with the IR-110 A

Compared to conventional butt welding, the infrared technology is distinguished by short fusion times, high reproducibility and highest reliability. The contact-free jointing of the components by IR-welding reduces the warm-up time by more than 30%, eliminating the adaptation, which often results in various weld bead formations. Sticking of the pipe

surface to the heating element is not possible. The IR-110 A from GF Piping Systems impresses with a fully automated welding process that reduces application errors and directly detects and reports faults. An integrated process and quality control system makes the welding process traceable and reportable at all times and ensures the best product quality.



Macro-image of IR (infrared) welding



Lateral cut of IR (infrared) welding

# Services of GF Piping Systems

Optimal planning, installation and operation

The specialists at GF Piping Systems support you throughout all phases of your project. They help you to optimally plan, install and operate your plastic piping system. Therefore, they reduce unnecessary time and material losses for you and keep downtimes and other risks as short as necessary.



## Recommended services

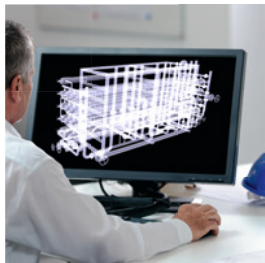

### Engineering

We check the design of your piping system, support you with the choice of materials and components as well as with the correct installation. Our 60 years of experience with plastic systems help you to reduce your own risks.

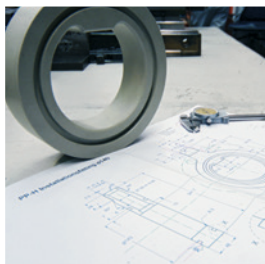

### Customizing

Customized special parts and solutions for special tasks are available in all required dimensions. Even unusual applications in challenging installation scenarios can be implemented easily, safely and on time.



### Digital Product Libraries

The digital product libraries by GF Piping Systems allow planning with real-life dimensions and automatically generated parts lists, facilitating digital cooperation. They help reduce planning errors and shorten your project times.

## Next steps

In this brochure you have received the most important information and technical details. But nothing replaces a personal conversation with an expert from GF Piping Systems. It is all about your needs and how we can support you in your daily business challenges. If you have not already done so, make an appointment today.

On the GF Piping Systems website you will find specialized contact persons in your area. There you will also find further information on the product, including technical data sheets and operating instructions as well as relevant certificates and approvals.

- Appointment with an expert from GF Piping Systems
- Advice on the benefits of the solution for you
- Information on reference applications
- Help with selection and calculations
- Support in all project phases

## More information

[www.gfps.com](http://www.gfps.com)



**SYGEF ECTFE**

# Product range







### SYGEF ECTFE pipe SDR21/PN10

**Model:**

- Material: ECTFE
- Length: Lengths of 5 m

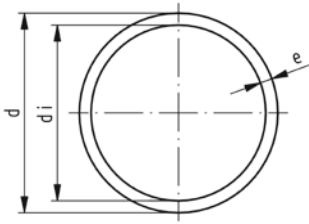

d (mm)	PN (bar)	FM	Code	Weight (kg)	e (mm)	di (mm)
20	10	IR	<b>177 480 106</b>	0.210	1.9	16.2
25	10	IR	<b>177 480 107</b>	0.269	1.9	21.2
32	10	IR	<b>177 480 108</b>	0.435	2.4	27.2
40	10	IR	<b>177 480 109</b>	0.563	2.4	35.2
50	10	IR	<b>177 480 110</b>	0.850	3.0	44.0
63	10	IR	<b>177 480 111</b>	1.090	3.0	57.0
75	10	IR	<b>177 480 112</b>	1.550	3.6	67.8
90	10	IR	<b>177 480 113</b>	2.230	4.3	81.4
110	10	IR	<b>177 480 114</b>	3.330	5.3	99.4

### SYGEF ECTFE bend 90° SDR21/PN10

**Model:**

- Material: ECTFE

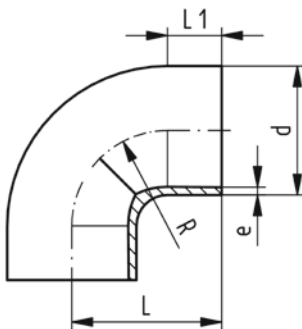

d (mm)	PN (bar)	FM	Code	Weight (kg)	e (mm)	L (mm)	L1 (mm)	R (mm)
20	10	IR	<b>737 018 106</b>	0.016	1.9	38	23	15
25	10	IR	<b>737 018 107</b>	0.022	1.9	42	23	19
32	10	IR	<b>737 018 108</b>	0.038	2.4	46	22	24
40	10	IR	<b>737 018 109</b>	0.055	2.4	51	21	30
50	10	IR	<b>737 018 110</b>	0.095	3.0	58	21	37
63	10	IR	<b>737 018 111</b>	0.138	3.0	66	21	45
75	10	IR	<b>737 018 112</b>	0.243	3.6	75	23	62
90	10	IR	<b>737 018 113</b>	0.423	4.3	90	23	77
110	10	IR	<b>737 018 114</b>	0.705	5.3	110	23	98

### SYGEF ECTFE elbow 45° SDR21/PN10

**Model:**

- Material: ECTFE

d (mm)	PN (bar)	FM	Code	Weight (kg)	e (mm)	L (mm)	L1 (mm)
20	10	IR	<b>737 158 106</b>	0.014	1.9	32	25
25	10	IR	<b>737 158 107</b>	0.019	1.9	34	26
32	10	IR	<b>737 158 108</b>	0.033	2.4	36	26
40	10	IR	<b>737 158 109</b>	0.042	2.4	39	28
50	10	IR	<b>737 158 110</b>	0.084	3.0	42	30
63	10	IR	<b>737 158 111</b>	0.121	3.0	47	31
75	10	IR	<b>737 158 112</b>	0.160	3.6	49	32
90	10	IR	<b>737 158 113</b>	0.271	4.3	57	37
110	10	IR	<b>737 158 114</b>	0.499	5.3	70	46

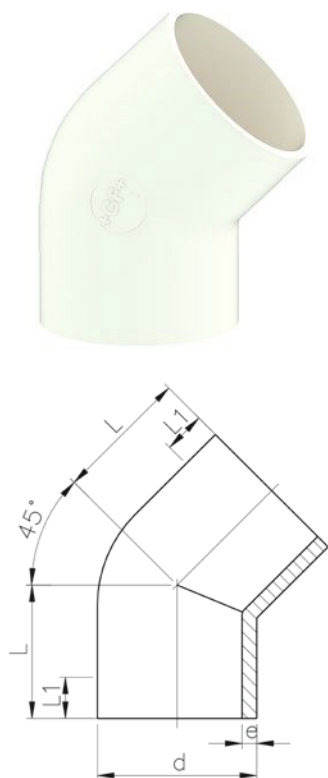

### SYGEF ECTFE tee 90° equal SDR21/PN10

**Model:**

- Material: ECTFE

d (mm)	PN (bar)	FM	Code	Weight (kg)	e (mm)	L (mm)	L1 (mm)
20	10	IR	<b>737 208 106</b>	0.023	1.9	38	25
25	10	IR	<b>737 208 107</b>	0.032	1.9	42	27
32	10	IR	<b>737 208 108</b>	0.056	2.4	46	27
40	10	IR	<b>737 208 109</b>	0.083	2.4	51	28
50	10	IR	<b>737 208 110</b>	0.156	3.0	58	28
63	10	IR	<b>737 208 111</b>	0.270	3.0	66	28
75	10	IR	<b>737 208 112</b>	0.336	3.6	75	32
90	10	IR	<b>737 208 113</b>	0.587	4.3	90	39
110	10	IR	<b>737 208 114</b>	1.054	5.3	110	48

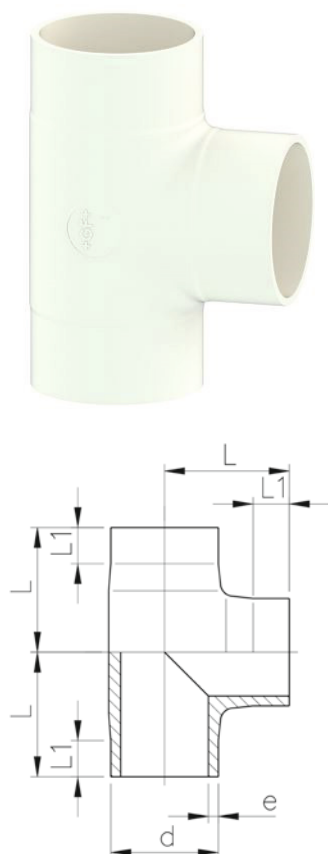

## SYGEF ECTFE reducer SDR21/PN10

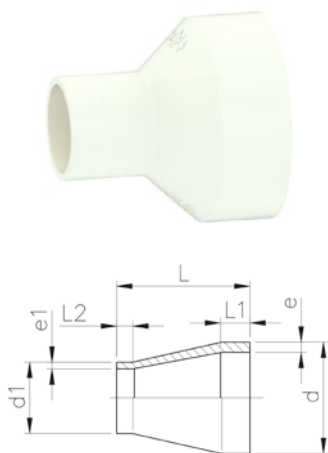

### Model:

- Material: ECTFE

d - d1 (mm)	PN (bar)	FM	Code	Weight (kg)	e (mm)	e1 (mm)	L (mm)	L1 (mm)	L2 (mm)
25 - 20	10	IR	<b>737 908 107</b>	0.013	1.9	1.9	50	22	22
32 - 20	10	IR	<b>737 908 108</b>	0.016	2.4	1.9	50	22	22
32 - 25	10	IR	<b>737 908 118</b>	0.017	2.4	1.9	50	22	22
40 - 20	10	IR	<b>737 908 109</b>	0.023	2.4	1.9	58	22	24
40 - 25	10	IR	<b>737 908 119</b>	0.022	2.4	1.9	55	22	24
40 - 32	10	IR	<b>737 908 129</b>	0.026	2.4	2.4	55	22	24
50 - 25	10	IR	<b>737 908 110</b>	0.034	3.0	1.9	60	22	25
50 - 32	10	IR	<b>737 908 120</b>	0.040	3.0	2.4	60	22	25
50 - 40	10	IR	<b>737 908 130</b>	0.039	3.0	2.4	60	22	25
63 - 32	10	IR	<b>737 908 111</b>	0.050	3.0	2.4	65	22	25
63 - 40	10	IR	<b>737 908 121</b>	0.052	3.0	2.4	65	22	25
63 - 50	10	IR	<b>737 908 131</b>	0.059	3.0	3.0	65	22	25
75 - 40	10	IR	<b>737 908 112</b>	0.078	3.6	2.4	68	24	25
75 - 50	10	IR	<b>737 908 122</b>	0.078	3.6	3.0	65	24	25
75 - 63	10	IR	<b>737 908 132</b>	0.082	3.6	3.0	65	24	25
90 - 63	10	IR	<b>737 908 113</b>	0.123	4.3	3.0	75	25	30
90 - 75	10	IR	<b>737 908 123</b>	0.136	4.3	3.6	75	25	35
110 - 63	10	IR	<b>737 908 114</b>	0.218	5.3	3.0	90	30	30
110 - 75	10	IR	<b>737 908 124</b>	0.224	5.3	3.6	90	30	35
110 - 90	10	IR	<b>737 908 134</b>	0.242	5.3	4.3	90	30	35

## SYGEF ECTFE end cap SDR21/PN10

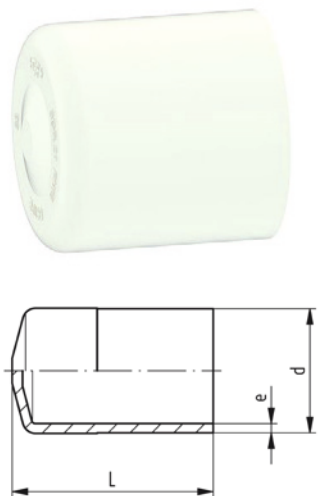

### Model:

- Material: ECTFE

d (mm)	PN (bar)	FM	Code	Weight (kg)	e (mm)	L (mm)
20	10	IR	<b>737 968 106</b>	0.009	1.9	47
25	10	IR	<b>737 968 107</b>	0.012	1.9	47
32	10	IR	<b>737 968 108</b>	0.022	2.4	52
40	10	IR	<b>737 968 109</b>	0.032	2.4	55
50	10	IR	<b>737 968 110</b>	0.054	3.0	59
63	10	IR	<b>737 968 111</b>	0.083	3.0	66
75	10	IR	<b>737 968 112</b>	0.124	3.6	67
90	10	IR	<b>737 968 113</b>	0.205	4.3	74
110	10	IR	<b>737 968 114</b>	0.349	5.3	82

### SYGEF ECTFE union SDR21/PN10

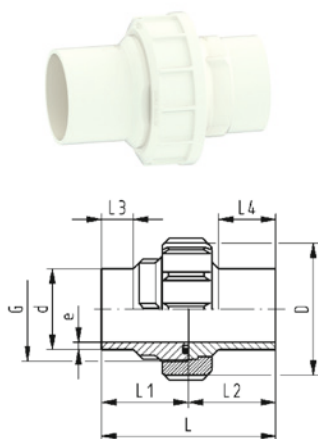

#### Model:

- Material: ECTFE
- O-Ring: FKM black; FFKM on request

d (mm)	PN (bar)	FM	Code	Weight (kg)	e (mm)	D (mm)	L (mm)	L1 (mm)	L2 (mm)	L3 (mm)	L4 (mm)	G (inch)
20	10	IR	<b>737 528 206</b>	0.082	1.9	43	106	53	53	24	37	1
25	10	IR	<b>737 528 207</b>	0.123	1.9	53	112	56	56	24	38	1 ¼
32	10	IR	<b>737 528 208</b>	0.166	2.4	60	118	59	59	24	40	1 ½
40	10	IR	<b>737 528 209</b>	0.263	2.4	74	124	62	62	24	41	2
50	10	IR	<b>737 528 210</b>	0.372	3.0	82	130	65	65	24	43	2 ¼
63	10	IR	<b>737 528 211</b>	0.463	3.0	100	136	68	68	24	44	2 ¾

### SYGEF ECTFE union end SDR21/PN10

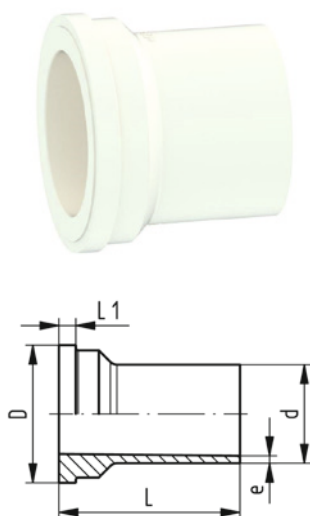

#### Model:

- Material: ECTFE
- suitable for SYGEF ECTFE union

d (mm)	PN (bar)	FM	Code	Weight (kg)	e (mm)	L (mm)	L1 (mm)	D (mm)
20	10	IR	<b>737 608 106</b>	0.020	1.9	53	5	30
25	10	IR	<b>737 608 107</b>	0.030	1.9	56	5	39
32	10	IR	<b>737 608 108</b>	0.044	2.4	59	6	45
40	10	IR	<b>737 608 109</b>	0.069	2.4	62	6	57
50	10	IR	<b>737 608 110</b>	0.083	3.0	65	7	63
63	10	IR	<b>737 608 111</b>	0.130	3.0	68	8	78

### SYGEF ECTFE union bush Type I SDR21/PN10

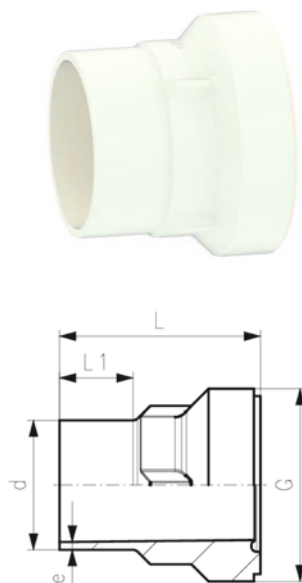

#### Model:

- Material: ECTFE
- gap filling O-ring positioning
- suitable for SYGEF ECTFE union

d (mm)	PN (bar)	FM	Code	Weight (kg)	e (mm)	L (mm)	L1 (mm)	G (inch)
20	10	IR	<b>737 648 106</b>	0.024	1.9	53	25	1
25	10	IR	<b>737 648 107</b>	0.038	1.9	56	25	1 ¼
32	10	IR	<b>737 648 108</b>	0.056	2.4	59	25	1 ½
40	10	IR	<b>737 648 109</b>	0.082	2.4	62	25	2
50	10	IR	<b>737 648 110</b>	0.113	3.0	65	25	2 ¼
63	10	IR	<b>737 648 111</b>	0.168	3.0	68	25	2 ¾

### SYGEF ECTFE union bush Type II SDR21/PN10

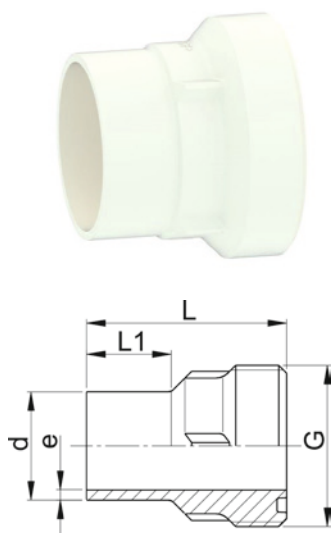

#### Model:

- Material: ECTFE
- Suitable for SYGEF ECTFE Union

d (mm)	PN (bar)	FM	Code	Weight (kg)	e (mm)	L (mm)	L1 (mm)	G (inch)
20	10	IR	<b>737 648 206</b>	0.025	1.9	53	25	1
25	10	IR	<b>737 648 207</b>	0.039	1.9	56	25	1 ¼
32	10	IR	<b>737 648 208</b>	0.055	2.4	59	25	1 ½
40	10	IR	<b>737 648 209</b>	0.081	2.4	62	25	2
50	10	IR	<b>737 648 210</b>	0.110	3.0	65	25	2 ¼
63	10	IR	<b>737 648 211</b>	0.158	3.0	68	25	2 ¾

### SYGEF ECTFE union nut SDR21/PN10



#### Model:

- Material: ECTFE

d (mm)	PN (bar)	Code	Weight (kg)	L (mm)	D (mm)	G (inch)
20	10	<b>737 690 106</b>	0.023	22	43	1
25	10	<b>737 690 107</b>	0.034	24	53	1 ¼
32	10	<b>737 690 108</b>	0.045	26	60	1 ½
40	10	<b>737 690 109</b>	0.070	29	74	2
50	10	<b>737 690 110</b>	0.100	33	82	2 ¼
63	10	<b>737 690 111</b>	0.151	35	100	2 ¾

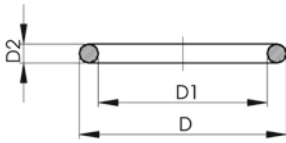

### O-ring white

#### Model:

- For unions with gap filling O-ring position
- Hardness approx. 65° Shore
- FKM white min. temperature -15°C

d (mm)	FKM Code	Weight (kg)	D (mm)	D1 (mm)	D2 (mm)
20	<b>749 411 005</b>	0.002	20.6	15.5	2.62
25	<b>749 411 006</b>	0.002	27.3	20.2	3.53
32	<b>749 411 120</b>	0.002	33.6	26.6	3.53
40	<b>749 411 062</b>	0.002	41.6	34.5	3.53
50	<b>749 411 172</b>	0.003	51.1	44.0	3.53
63	<b>749 411 054</b>	0.003	63.0	55.0	4.00
75	<b>749 411 013</b>	0.010	79.9	69.2	5.33
90	<b>749 411 014</b>	0.012	92.6	81.9	5.33
110	<b>749 411 015</b>	0.015	117.0	101.0	5.33

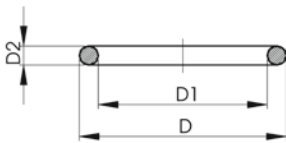

### O-Ring gasket

#### Model:

- For unions and adaptor unions
- Hardness approx. 65° Shore
- EPDM minimum temperature -40°C
- FKM minimum temperature -15°C

\* For unions PVC-U, PVC-C and ABS: 21 51 01, 21 51 11, 21 53 03, 21 53 08, 21 55 04, 21 55 13, 21 55 18, 23 51 01 and 29 51 01 only

d (mm)	DN (mm)	EPDM Code	Weight (kg)	FKM Code	Weight (kg)
10 - 12	8	<b>748 410 004</b>	0.002	<b>749 410 004</b>	0.002
16	10	<b>748 410 005</b>	0.004	<b>749 410 005</b>	0.002
20	15	<b>748 410 006</b>	0.002	<b>749 410 006</b>	0.002
25	20	<b>748 410 007</b>	0.002	<b>749 410 007</b>	0.002
32	25	<b>748 410 008</b>	0.003	<b>749 410 008</b>	0.002
40	32	<b>748 410 009</b>	0.003	<b>749 410 009</b>	0.007
50	40	<b>748 410 010</b>	0.004	<b>749 410 010</b>	0.006
63	50	<b>748 410 011</b>	0.005	<b>749 410 011</b>	0.003
75	65	<b>748 410 014</b>	0.007	<b>749 410 014</b>	0.012
90	80	<b>748 410 015</b>	0.008	<b>749 410 015</b>	0.015
*	90	<b>748 410 248</b>	0.008	<b>749 410 248</b>	0.020
110	100	<b>748 410 016</b>	0.016	<b>749 410 016</b>	0.031

d (mm)	DN (mm)	D (mm)	D1 (mm)	D2 (mm)	closest inch (inch)
10 - 12	8	17.62	12.37	2.62	¼
16	10	20.78	15.54	2.62	¾
20	15	27.28	20.22	3.53	½
25	20	35.23	28.17	3.53	¾
32	25	39.99	32.93	3.53	1
40	32	51.33	40.65	5.34	1 ¼
50	40	57.68	46.99	5.34	1 ½
63	50	70.37	59.69	5.34	2
75	65	92.60	81.92	5.34	2 ½
90	80	111.68	101.00	5.34	3
*	90	105.30	94.62	5.34	3
110	100	134.00	120.20	6.99	4

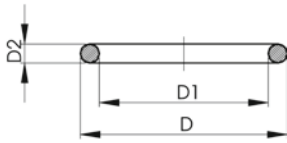

## O-Ring Gaskets

### Model:

- For unions and adaptor unions
- Hardness approx. 75° shore
- FFKM minimum temperature -20°C

d (mm)	DN (mm)	FFKM Code	Weight (kg)	D (mm)	D1 (mm)	D2 (mm)
20	15	<b>700 245 481</b>	0.002	27	20	3.53
25	20	<b>700 245 482</b>	0.002	35	28	3.53
32	25	<b>700 245 483</b>	0.002	40	33	3.53
40	32	<b>700 245 484</b>	0.006	51	41	5.33
50	40	<b>700 245 485</b>	0.007	58	47	5.33
63	50	<b>700 245 486</b>	0.010	70	60	5.33



## SYGEF ECTFE flare transition fitting SDR21/PN10

### Model:

- Material: ECTFE

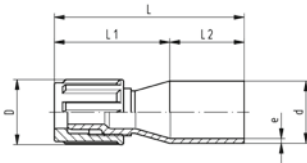

d (mm)	tube size (inch)	PN (bar)	FM	Code	Weight (kg)	e (mm)	L (mm)	L1 (mm)	L2 (mm)	D (mm)
20	¾	10	IR	<b>737 598 106</b>	0.028	1.9	75	45	30	20
20	¾	10	IR	<b>737 598 116</b>	0.022	1.9	76	46	30	23
20	½	10	IR	<b>737 598 126</b>	0.034	1.9	76	46	30	26
20	¾	10	IR	<b>737 598 136</b>	0.043	1.9	78	48	30	34
25	¾	10	IR	<b>737 598 107</b>	0.033	1.9	75	45	30	20
25	¾	10	IR	<b>737 598 117</b>	0.025	1.9	76	46	30	23
25	½	10	IR	<b>737 598 127</b>	0.028	1.9	76	46	30	26
25	¾	10	IR	<b>737 598 137</b>	0.048	1.9	78	48	30	34
25	1	10	IR	<b>737 598 147</b>	0.049	1.9	87	57	30	46
32	½	10	IR	<b>737 598 128</b>	0.036	2.4	76	46	30	26
32	¾	10	IR	<b>737 598 138</b>	0.050	2.4	78	48	30	34
32	1	10	IR	<b>737 598 148</b>	0.050	2.4	87	57	30	46

## SYGEF ECTFE flange adaptor ISO serrated SDR21/PN10

### Model:

- Material: ECTFE

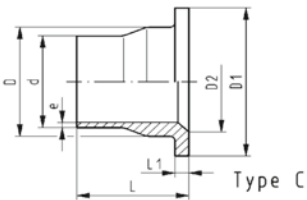
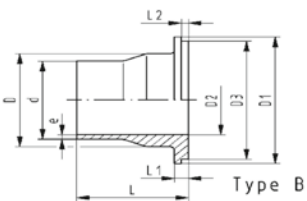
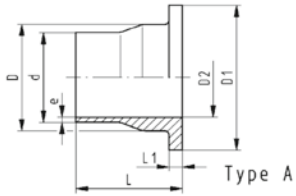

d (mm)	DN (mm)	PN (bar)	FM	Code	Weight (kg)
20	15	10	IR	<b>737 798 106</b>	0.029
25	20	10	IR	<b>737 798 107</b>	0.044
32	25	10	IR	<b>737 798 108</b>	0.066
40	32	10	IR	<b>737 798 109</b>	0.088
50	40	10	IR	<b>737 798 110</b>	0.146
63	50	10	IR	<b>737 798 111</b>	0.215
75	65	10	IR	<b>737 798 112</b>	0.325
90	80	10	IR	<b>737 798 113</b>	0.397
110	100	10	IR	<b>737 798 114</b>	0.573

e (mm)	D (mm)	D1 (mm)	D2 (mm)	D3 (mm)	L (mm)	L1 (mm)	L2 (mm)	Type
1.9	26	45	15		54	6	53	A
1.9	32	58	20	54	56	7	4	B
2.4	40	68	26	63	58	7	4	B
2.4	49	78	34	73	68	8	4	B
3.0	60	88	43	82	69	8	4	B
3.0	75	102	56		72	9		A
3.6	89	122	66		80	10		A
4.3	105	138	78	133	81	12	4	B
5.3	125	158	100		81	13		C

## SYGEF ECTFE flange adaptor ANSI serrated SDR21/PN10

### Model:

- Material: ECTFE

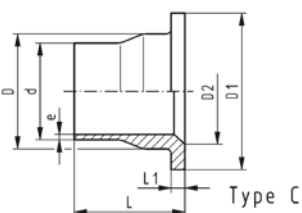
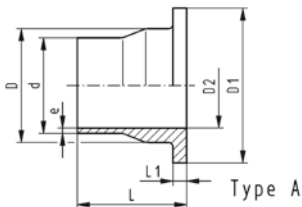

d (inch)	d (mm)	DN (mm)	PN (bar)	FM	Code	Weight (kg)	e (mm)	D (mm)	D1 (mm)	D2 (mm)	L (mm)	L1 (mm)	Type
½	20	15	10	IR	<b>737 798 106</b>	0.029	1.9	26	45	15	54	6	A
¾	25	20	10	IR	<b>737 798 157</b>	0.043	1.9	32	54	20	56	7	A
1	32	25	10	IR	<b>737 798 158</b>	0.063	2.4	40	63	26	58	7	A
1 ¼	40	32	10	IR	<b>737 798 159</b>	0.089	2.4	49	72	34	68	8	A
1 ½	50	40	10	IR	<b>737 798 160</b>	0.140	3.0	60	82	43	69	8	A
2	63	50	10	IR	<b>737 798 111</b>	0.215	3.0	75	102	56	72	9	A
2 ½	75	65	10	IR	<b>737 798 112</b>	0.325	3.6	89	122	66	80	10	A
3	90	80	10	IR	<b>737 798 163</b>	0.389	4.3	105	138	78	81	12	A
4	110	100	10	IR	<b>737 798 114</b>	0.573	5.3	125	158	100	81	13	C



## SYGEF ECTFE valve End SDR21/PN10



### Model:

- Material: ECTFE
- Suitable for Ball valve 546

d	DN	PN	FM	Code	Weight	e	D	L	L1	L2
(mm)	(mm)	(bar)			(kg)	(mm)	(mm)	(mm)	(mm)	(mm)
20	15	10	IR	<b>177 483 048</b>	0.019	1.9	38	37	4	25
25	20	10	IR	<b>177 483 049</b>	0.026	1.9	44	39	5	25
32	25	10	IR	<b>177 483 050</b>	0.043	2.4	53	40	5	25
40	32	10	IR	<b>177 483 051</b>	0.065	2.4	65	43	5	25
50	40	10	IR	<b>177 483 052</b>	0.100	3.0	77	51	6	25
63	50	10	IR	<b>177 483 053</b>	0.150	3.0	99	60	7	28
75	65	10	IR	<b>177 483 054</b>	0.348	3.6	125	65	9	41
90	80	10	IR	<b>177 483 055</b>	0.507	4.3	150	62	10	33
110	100	10	IR	<b>177 483 056</b>	0.820	5.3	180	69	11	37

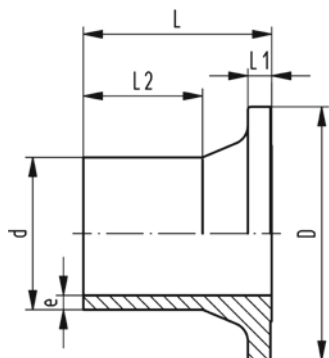

## Backing flange PP-Steel metric For butt fusion systems metric



### Model:

- Material: PP (30% glass-fibre reinforced) with steel ring
- Connecting dimension: ISO 7005, EN 1092, BS 4504, DIN 2501
- **Bolt circle PN 10**

AL: number of holes

<sup>1)</sup> Suitable for socket -and butt fusion systems

<sup>2)</sup> Combined version, bolt circle metric - ANSI

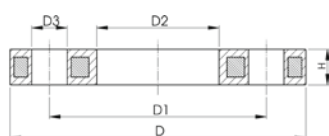

	d	DN	PN	Code	Weight	D	D1	D2	D3	H max.	AL	SC
	(mm)	(mm)	(bar)		(kg)	(mm)	(mm)	(mm)	(mm)	(mm)		
1	20	15	16	<b>727 700 206</b>	0.216	95	65	28	14	12	4	M12
1	25	20	16	<b>727 700 207</b>	0.279	105	75	34	14	12	4	M12
1	32	25	16	<b>727 700 208</b>	0.429	115	85	42	14	16	4	M12
1	40	32	16	<b>727 700 209</b>	0.621	140	100	51	18	16	4	M16
1	50	40	16	<b>727 700 210</b>	0.722	150	110	62	18	20	4	M16
1	63	50	16	<b>727 700 211</b>	0.900	165	125	78	18	20	4	M16
1	75	65	16	<b>727 700 212</b>	1.110	185	145	92	18	20	4	M16
	90	80	16	<b>727 700 313</b>	1.390	200	160	108	18	20	8	M16
	110	100	16	<b>727 700 314</b>	1.407	220	180	128	18	20	8	M16
	125	100	16	<b>727 700 315</b>	1.408	220	180	135	18	20	8	M16
	140	125	16	<b>727 700 716</b>	2.318	250	210	158	18	26	8	M16
2	160	150	16	<b>727 700 717</b>	3.491	285	241	178	22	26	8	M20
	180	150	16	<b>727 700 718</b>	3.108	285	241	188	22	26	8	M20
2	200	200	16	<b>727 700 719</b>	5.600	340	297	235	22	29	8	M20
2	225	200	16	<b>727 700 720</b>	5.533	340	297	238	22	29	8	M20
	250	250	16	<b>727 700 721</b>	6.632	395	350	288	22	32	12	M20
	280	250	16	<b>727 700 722</b>	6.573	395	350	294	22	32	12	M20
	315	300	16	<b>727 700 723</b>	7.903	445	400	338	22	36	12	M20
	355	350	16	<b>727 700 724</b>	14.587	515	460	376	23	42	16	M20
	400	400	16	<b>727 700 725</b>	20.034	574	515	430	26	42	16	M24



### Backing flange PP-Steel Inch/ANSI For butt fusion systems metric

**Model:**

- Material: PP (30% glass-fibre reinforced) with steel ring
- Connecting dimension: ANSI/ASME B 16.5 class 150, ASTM D 4024, BS 1560, BS EN 1759
- **Bolt circle class 150**
- Special flange adapter ANSI for d25 - d50 and d90 required

<sup>1)</sup> Suitable for socket -and butt fusion systems

<sup>2)</sup> Combined version, bolt circle metric - ANSI

AL: number of holes

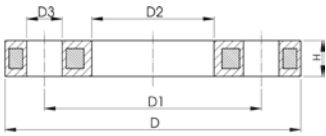

	d (inch)	d (mm)	DN (mm)	PN (bar)	Code	Weight (kg)
1	½	20	15	16	<b>727 701 206</b>	0.213
1	¾	25	20	16	<b>727 701 207</b>	0.260
1	1	32	25	16	<b>727 701 208</b>	0.416
1	1 ¼	40	32	16	<b>727 701 209</b>	0.730
1	1 ½	50	40	16	<b>727 701 210</b>	0.809
1	2	63	50	16	<b>727 701 211</b>	0.866
1	2 ½	75	65	16	<b>727 701 212</b>	1.117
	3	90	80	16	<b>727 701 313</b>	1.499
	4	110	100	16	<b>727 701 314</b>	1.739
2	6	160	150	16	<b>727 700 717</b>	3.491
2	8	200	200	16	<b>727 700 719</b>	5.600
2	8	225	200	16	<b>727 700 720</b>	5.533
	10	250/280	250	10	<b>727 701 321</b>	6.000
	12	315	300	10	<b>727 701 322</b>	11.800
	14	355	350	10	<b>727 701 323</b>	17.900

### Profile Flange Gaskets ANSI

**Model:**

- Suitable for flanges adaptors PP/PE PVDF
- Hardness: 70° Shore EPDM, 75° Shore FKM
- Centered by the flange bolts
- Dimension D is in accordance with the inner diameter of the bolt circle

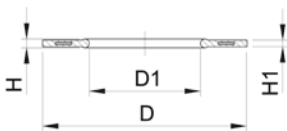

d (mm)	EPDM Code	Weight (kg)	FKM Code	Weight (kg)	Inch (inch)	DN (mm)	D (mm)	D1 (mm)	H (mm)	H1 (mm)
25	<b>748 440 502</b>	0.010	<b>749 440 502</b>	0.011	3/4	20	54	27	4	3
32	<b>748 440 503</b>	0.011	<b>749 440 503</b>	0.023	1	25	64	33	4	3
40	<b>748 440 504</b>	0.017	<b>749 440 504</b>	0.024	1 1/4	32	73	42	4	3
50	<b>748 440 505</b>	0.030	<b>749 440 505</b>	0.030	1 1/2	40	83	48	4	3
63	<b>748 440 506</b>	0.029	<b>749 440 506</b>	0.042	2	50	102	60	5	4
75	<b>748 440 507</b>	0.046	<b>749 440 507</b>	0.068	2 1/2	65	121	73	5	4
90	<b>748 440 508</b>	0.053	<b>749 440 508</b>	0.083	3	80	133	89	5	4
110	<b>748 440 509</b>	0.088	<b>749 440 509</b>	0.139	4	100	171	115	6	5
160 - 180	<b>748 440 512</b>	0.127	<b>749 440 512</b>	0.240	6	150	222	160	8	6
225	<b>748 440 515</b>	0.195	<b>749 440 515</b>	0.316	8	200	279	220	8	6
250	<b>748 440 517</b>	0.243	<b>749 440 517</b>	0.373	10	250	337	273	8	6
315	<b>748 440 518</b>	0.398	<b>749 440 518</b>	0.750	12	300	406	325	8	6
355	<b>748 440 519</b>	0.800	<b>749 440 519</b>	0.800	14	350	448	356	10	7
400	<b>748 440 520</b>	0.900	<b>749 440 520</b>	0.900	16	400	512	406	10	7
450	<b>748 440 521</b>	1.000	<b>749 440 521</b>	1.000	18	450	547	457	10	7
500	<b>748 440 522</b>	1.000	<b>749 440 522</b>	1.000	20	500	604	508	10	7

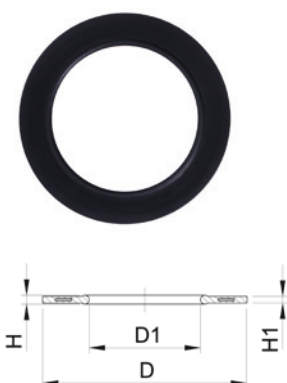

## Profile Flange Gasket, metric EPDM / FKM

### Model:

- For all metric GF Flange Adaptors
  - Hardness: 70° Shore EPDM, 75° Shore FKM
  - EPDM: approved acc. to DVGW Water W 270, KTW recommendation
  - Centering on the inner diameter of the screw crown
  - material steel insert: carbon steel
  - Rubber-steel body combined with rubber profile cord ring
- di FA are the suitable inner diameters of flanges adaptors

d (mm)	PN (bar)	DN (mm)	EPDM Code	FKM Code	Weight (kg)	D (mm)	D1 (mm)	di FA (mm)	H (mm)	H1 (mm)
16	16	10	748 440 705	749 440 705	0.012	46	16	6 - 16	4	3
20	16	15	748 440 706	749 440 706	0.013	51	20	10 - 20	4	3
25	16	20	748 440 707	749 440 707	0.014	61	22	12 - 22	4	3
32	16	25	748 440 708	749 440 708	0.019	71	28	18 - 28	4	3
40	16	32	748 440 709	749 440 709	0.026	82	40	30 - 40	4	3
50	16	40	748 440 710	749 440 710	0.039	92	46	36 - 46	4	3
63	16	50	748 440 711	749 440 711	0.050	107	58	48 - 58	5	4
75	16	65	748 440 712	749 440 712	0.082	127	69	59 - 69	5	4
90	16	80	748 440 713	749 440 713	0.083	142	84	73 - 84	5	4
110	16	100	748 440 714	749 440 714	0.127	162	104	94 - 104	6	5
125	16	100	748 440 715	749 440 715	0.105	162	123	113 - 123	6	5
140	16	125	748 440 716	749 440 716	0.173	192	137	127 - 137	6	5
160 - 180	16	150	748 440 717	749 440 717	0.207	218	160	150 - 160	8	6
200	16	200	748 440 719	749 440 719	0.263	273	203	192 - 203	8	6
225	16	200	748 440 720	749 440 720	0.255	273	220	207 - 220	8	6
250	16	250	748 440 721	749 440 721	0.462	328	252	238 - 252	8	6
280	16	250	748 440 722	749 440 722	0.323	328	274	264 - 274	8	6
315	16	300	748 440 723	749 440 723	0.549	378	306	296 - 306	8	6
355	16	350	748 440 724	749 440 724	0.870	438	355	340 - 355	10	7
400	16	400	748 440 725	749 440 725	1.088	489	400	385 - 400	10	7
450	16	500	748 440 726	749 440 726	0.718	594	403	393 - 403	10	7
500	16	500	748 440 727	749 440 727	0.718	594	447	437 - 447	10	7
560	16	600	748 440 728	749 440 728	0.923	695	494	484 - 494	10	7
630	16	600	748 440 729	749 440 729	0.923	695	555	545 - 555	10	7

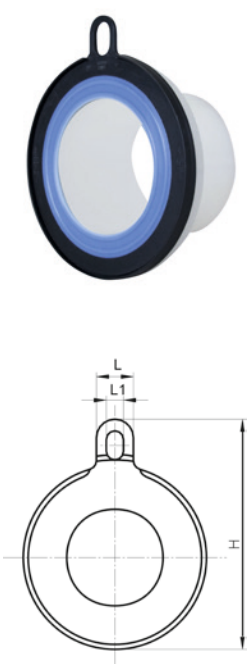

## SYGEF Plus Gasket

### Model:

- For Use with Steel Flange Rings
- \* Non-Returnable/Non-Cancelable

d (mm)	Pipe Size (inch)	Code	Weight (lb)	H (inch)	L (inch)	L1 (inch)
25	3/4	731 400 753	0.044	2.99	0.79	0.51
32	1	731 400 755	0.053	3.58	0.98	0.63
40	1 1/4	731 400 757	0.079	3.98	0.98	0.63
50	1 1/2	731 400 759	0.084	4.33	0.98	0.63
63	2	731 400 760	0.132	5.04	0.98	0.63
75	2 1/2	731 400 761	0.179	5.83	0.98	0.63
90	3	731 400 763	0.132	6.34	0.98	0.63
110	4	731 400 764	0.220	7.44	0.98	0.63
160	6	731 400 667	0.309	9.61	1.18	0.79
200/225	8/9	731 400 670	0.441	11.81	1.18	0.79
250	10	731 400 671	0.683	14.17	1.38	0.87
315	12	731 400 672	0.650	16.50	1.38	0.87

### Type SDV Diaphragm Valve - with Handwheel - SYGEF ECTFE

#### Model:

- ISO/ DIN flange connection
- Material: PFA lined SSSt valve body, PTFE-T/FKM diaphragm

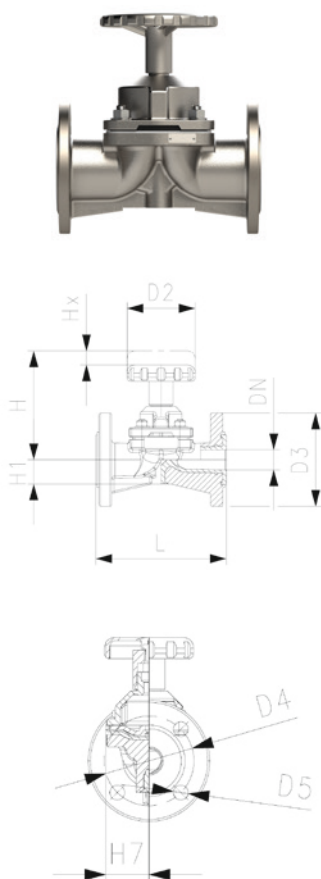

d (inch)	d (mm)	DN (mm)	PN (bar)	Code	Weight (kg)
½	20	15	10	<b>160 144 106</b>	2.5
¾	25	20	10	<b>160 144 107</b>	3.0
1	32	25	10	<b>160 144 108</b>	3.8
1 ¼	40	32	10	<b>160 144 109</b>	5.2
1 ½	50	40	10	<b>160 144 110</b>	7.4
2	63	50	10	<b>160 144 111</b>	9.7
2 ½	75	65	10	<b>160 144 112</b>	13.5
3	90	80	8	<b>160 144 113</b>	18.0
4	110	100	7	<b>160 144 114</b>	30.0

L (mm)	D2 (mm)	D3 (mm)	D4 (mm)	D5 (mm)	H (mm)	H1 (mm)	H7 (mm)	Hx (mm)	Rotation (per stroke)	kv-value (m³/h)
130	85	95	65	14	115	24	36	8	4.5	7.8
150	85	105	75	14	117	26	36	8	4.5	10.0
160	85	115	85	14	124	30	41	10	5.5	15.0
180	85	140	100	18	134	35	52	12	7.0	22.5
200	120	150	110	18	173	41	56	24	12.0	37.0
230	120	165	125	18	186	44	70	30	15.0	65.0
290	180	185	145	18	208	55	82	30	12.0	95.0
310	180	200	160	18	233	60	100	34	13.5	134.0
350	250	220	180	18	282	72	123	40	13.5	200.0

### Type SDV Diaphragm Valve - with Handwheel - SYGEF ECTFE

#### Model:

- ANSI flange connection
- Material: PFA lined SSSt valve body, PTFE-T/FKM diaphragm

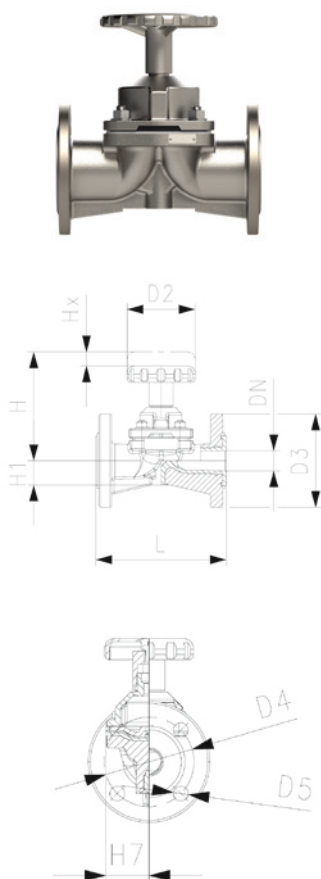

d (inch)	d (mm)	DN (mm)	PN (bar)	Code	Weight (kg)
½	20	15	10	<b>160 144 156</b>	2.5
¾	25	20	10	<b>160 144 157</b>	3.0
1	32	25	10	<b>160 144 158</b>	3.5
1 ¼	40	32	10	<b>160 144 159</b>	5.2
1 ½	50	40	10	<b>160 144 160</b>	6.3
2	63	50	10	<b>160 144 161</b>	9.0
2 ½	75	65	10	<b>160 144 162</b>	13.5
3	90	80	8	<b>160 144 163</b>	16.9
4	110	100	7	<b>160 144 164</b>	30.3

L (mm)	D2 (mm)	D3 (mm)	D4 (mm)	D5 (mm)	H (mm)	H1 (mm)	H7 (mm)	Hx (mm)	Rotation (per stroke)	kv-value (m³/h)
130	85	95	65	14	115	24	36	8	4.5	7.8
150	85	105	75	14	117	26	36	8	4.5	10.0
146	85	108	85	14	124	30	41	10	5.5	15.0
180	85	140	100	18	134	35	52	12	7.0	22.5
174	120	127	110	18	173	41	56	24	12.0	37.0
200	120	152	125	18	186	44	70	30	15.0	65.0
290	180	185	145	18	208	55	82	30	12.0	95.0
260	180	190	160	18	233	60	100	34	13.5	134.0
327	250	229	180	18	282	72	123	40	13.5	200.0

**Type SDV Diaphragm Valve - with pneumatic actuator - SYGEF ECTFE  
FC (fail safe to close)**

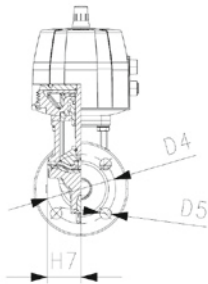
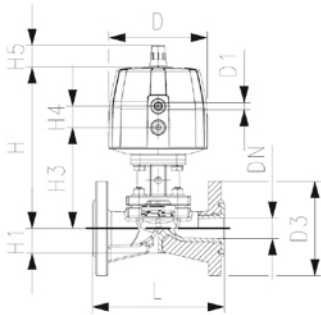

**Model:**

- ISO/ DIN flange connection
- Material: PFA lined SSSt valve body, PTFE-T/FKM diaphragm
- With pneumatic actuator

d (inch)	d (mm)	DN (mm)	PN (bar)	Code	Weight (kg)
½	20	15	10	<b>160 144 206</b>	4.8
¾	25	20	10	<b>160 144 207</b>	5.3
1	32	25	10	<b>160 144 208</b>	6.4
1 ¼	40	32	10	<b>160 144 209</b>	7.8
1 ½	50	40	10	<b>160 144 210</b>	13.9
2	63	50	10	<b>160 144 211</b>	16.0
2 ½	75	65	10	<b>160 144 212</b>	19.8
3	90	80	8	<b>160 144 213</b>	32.8
4	110	100	7	<b>160 144 214</b>	46.7

L (mm)	D (mm)	D1 (inch)	D3 (mm)	D4 (mm)	D5 (mm)	H (mm)	H1 (mm)	H3 (mm)	H4 (mm)	H5 (mm)	H7 (mm)	kv-value (m <sup>3</sup> /h)
130	96	⅜	95	65	14	211	24	115	26	23	36	7.8
150	96	⅜	105	75	14	213	26	117	26	23	36	10.0
160	96	⅜	115	85	14	227	30	123	26	23	41	15.0
180	120	¼	140	100	18	253	35	141	36	36	52	22.5
200	150	¼	150	110	18	284	41	154	37	36	56	37.0
230	150	¼	165	125	18	302	44	159	37	36	70	65.0
290	280	¼	185	145	18	366	55	182	24	46	82	95.0
310	280	¼	200	160	18	373	60	200	24	46	100	134.0
350	335	¼	220	180	18	448	72	267	24	46	123	200.0

**Type SDV Diaphragm Valve - with pneumatic actuator - SYGEF ECTFE  
FC (fail safe to close)**

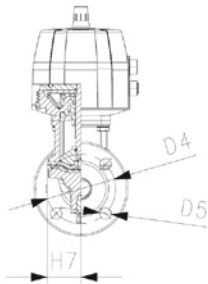
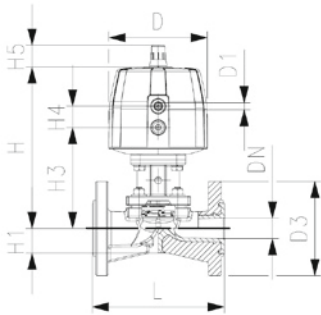

**Model:**

- ANSI flange connection
- Material: PFA lined SSSt valve body, PTFE-T/FKM diaphragm
- With pneumatic actuator

d (inch)	d (mm)	DN (mm)	PN (bar)	Code	Weight (kg)
½	20	15	10	<b>160 144 256</b>	4.8
¾	25	20	10	<b>160 144 257</b>	5.3
1	32	25	10	<b>160 144 258</b>	6.1
1 ¼	40	32	10	<b>160 144 259</b>	7.8
1 ½	50	40	10	<b>160 144 260</b>	12.8
2	63	50	10	<b>160 144 261</b>	15.3
2 ½	75	65	10	<b>160 144 262</b>	19.8
3	90	80	8	<b>160 144 263</b>	31.7
4	110	100	7	<b>160 144 264</b>	47.0

L (mm)	D (mm)	D1 (inch)	D3 (mm)	D4 (mm)	D5 (mm)	H (mm)	H1 (mm)	H3 (mm)	H4 (mm)	H5 (mm)	H7 (mm)	kv-value (m <sup>3</sup> /h)
130	96	⅜	95	65	14	211	24	115	26	23	36	7.8
150	96	⅜	105	75	14	213	26	117	26	23	36	10.0
146	96	⅜	115	85	14	227	30	123	26	23	41	15.0
180	120	¼	140	100	18	253	35	141	36	36	52	22.5
174	150	¼	150	110	18	284	41	154	37	36	56	37.0
200	150	¼	165	125	18	302	44	159	37	36	70	65.0
290	280	¼	185	145	18	366	55	182	24	46	82	95.0
260	280	¼	200	160	18	373	60	200	24	46	100	134.0
327	335	¼	220	180	18	448	72	267	24	46	123	200.0



### KLIP-IT spacer type 061 PP

**Model:**

- For pipe clips type 061/061H, PP black, UV resistant
- **Minimum order quantity: standard packaging SP**

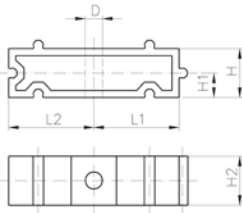

d (mm)	Inch (inch)	Code	Weight (kg)	D (mm)	H (mm)	H1 (mm)	H2 (mm)	L1 (mm)	L2 (mm)	SC
10 - 12	1/8 - 1/4	<b>167 061 153</b>	0.003	5	20	10	12	11	14	M4
16	3/8	<b>167 061 155</b>	0.005	6	20	10	16	14	17	M5
20	1/2	<b>167 061 156</b>	0.005	6	20	10	16	17	19	M5
25	3/4	<b>167 061 157</b>	0.007	6	20	10	16	19	22	M5
32	1	<b>167 061 158</b>	0.006	6	20	10	16	24	27	M5
40	1 1/4	<b>167 061 159</b>	0.015	7	20	10	22	34	34	M6
50	1 1/2	<b>167 061 160</b>	0.017	7	20	10	22	37	37	M6
63	2	<b>167 061 161</b>	0.020	9	20	10	25	45	45	M8
75	2 1/2	<b>167 061 162</b>	0.027	9	20	10	25	52	52	M8
90	3	<b>167 061 163</b>	0.039	9	20	10	28	65	65	M8
110	4	<b>167 061 164</b>	0.048	9	20	10	28	79	79	M8
140	5	<b>167 061 166</b>	0.065	9	20	10	32	98	98	M8

## KLIP-IT pipe clip type 061 PP metric

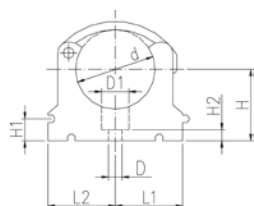

### Model:

- Material: clip and safety clip PP black, UV resistant
- d16 - d63: Height designed for Ball Valve Type 546 and 543
- **Minimum order quantity: standard packagings SP**

	d (mm)	d (inch)	Code	SP	Weight (kg)
*	10		<b>167 061 003</b>	10	0.003
*	12		<b>167 061 004</b>	10	0.003
*	16		<b>167 061 035</b>	10	0.007
*	20		<b>167 061 036</b>	10	0.007
*	25		<b>167 061 037</b>	10	0.009
*	32		<b>167 061 038</b>	10	0.012
	40		<b>167 061 039</b>	10	0.027
	50		<b>167 061 040</b>	10	0.031
	63		<b>167 061 041</b>	10	0.052
	75	2 ½	<b>167 061 012</b>	10	0.057
	90	3	<b>167 061 013</b>	10	0.092
	110	4	<b>167 061 014</b>	10	0.117
	125		<b>167 061 015</b>	10	0.180
	140	5	<b>167 061 016</b>	10	0.224
	160		<b>167 061 017</b>	10	0.242

	d (mm)	D (mm)	D1 (mm)	H (mm)	H1 (mm)	H2 (mm)	H3 (mm)	L1 (mm)	L2 (mm)	SC	closest inch (inch)
*	10	5	8	20	10	6	12	11	14	M4	⅜
*	12	5	8	21	10	6	12	11	14	M5	¼
*	16	6	11	27	10	6	16	14	17	M5	⅜
*	20	6	11	27	10	6	16	17	19	M5	½
*	25	6	11	30	10	6	16	19	22	M5	¾
*	32	6	11	36	10	6	16	24	27	M5	1
	40	7	14	44	10	7	22	34	34	M6	1 ¼
	50	7	14	51	10	7	22	37	37	M6	1 ½
	63	9	17	64	10	10	25	45	45	M8	2
	75	9	17	58	10	10	25	52	52	M8	2 ½
	90	9	17	65	10	10	28	65	65	M8	3
	110	9	17	75	10	10	28	79	79	M8	4
	125	9	17	90	10	10	32	88	88	M8	
	140	9	17	110	10	10	32	98	98	M8	5
	160	9	17	108	10	10	32	109	109	M8	6



### Pipe clip type 060 PP metric

#### Model:

- Material: clip and safety clip PP black, UV resistant
- **Minimum order quantity: standard packaging SP or gross packaging GP**
- Accidental opening of the safety clip is not possible
- Clip and safety clip are not assembled in the packaging
- Pipes with flanges can be installed directly

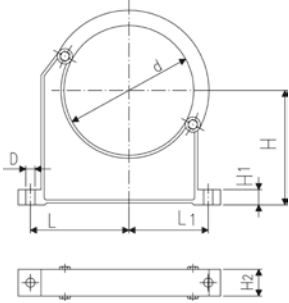

d (mm)	Code	SP	Weight (kg)	D (mm)	L (mm)	L1 (mm)	H (mm)	H1 (mm)	H2 (mm)	SC	closest inch (inch)
90	167 060 038	10	0.144	9	89	71	105	15	33	M 8	3
110	167 060 039	10	0.158	9	94	80	115	15	33	M 8	4
125	167 060 040	10	0.249	11	116	91	130	20	35	M10	
140	167 060 041	10	0.260	11	121	98	130	20	35	M10	5
160	167 060 042	10	0.296	11	131	107	148	20	35	M10	6
180	167 060 043	10	0.327	11	143	115	163	20	35	M10	7
200	167 060 019	5	0.539	13	152	120	175	25	39	M12	8
225	167 060 020	5	0.178	13	165	132	175	25	39	M12	8
250	167 060 021	5	0.657	13	183	143	200	25	39	M12	9
280	167 060 022	5	0.212	13	198	156	200	25	39	M12	10
315	167 060 023	5	0.805	13	219	172	225	25	39	M12	12
355	167 060 024	5	1.251	17	275	209	258	30	50	M16	14
400	167 060 025	4	1.031	17	300	228	288	30	50	M16	16



### IR-110 A Automated Fusion Machine

#### Model:

- Fully equipped automated infrared fusion machine with integrated working table for use under clean room conditions
- Welding of PVDF SYGEF (Standard/Plus), ECTFE SYGEF, PP grey PROGEF (Standard/Plus), PP-n PROGEF Natural, PE100 ecoFIT
- Dimensions d20-110 mm
- User friendly touch-screen interface 12.1" with various languages
- 4 USB interfaces, LAN Ethernet interface, 230 V Output
- Automated facer, clamping slide and heater
- Integrated video camera and temperature sensors
- Movable clamping units
- Clamping inserts d20-90 mm (8 pcs. per dimension)
- End caps PE d20-110 mm (4 pcs. per dimension)
- Shavings collection tray
- Transport box with integrated pallet
- 1-phase AC (50/60 Hz) 230V L/N/PE
- Power supply cable 230V EU Standard
- Torx key for facing blades (KW3)
- Cleaning brush
- Label printer
- Instruction manual

d-d (mm)	Code	SP	Weight (kg)
20 - 110	790 164 001	1	250.000





### Clamping inserts

- The clamping inserts are different for each dimension. They are used to clamp and position the pipe components.

d (mm)	Code	SP	Weight (kg)	Pieces
20	<b>790 164 022</b>	0	0.099	1
25	<b>790 164 023</b>	0	0.097	1
32	<b>790 164 024</b>	0	0.093	1
40	<b>790 164 025</b>	0	0.088	1
50	<b>790 164 026</b>	0	0.081	1
63	<b>790 132 156</b>	0	0.085	1
75	<b>790 132 157</b>	0	0.087	1
90	<b>790 132 158</b>	0	0.064	1



### Set of facing knives

- A set includes two facing knives and six screws. Each facing knife has four blades. The blade may be turned three times before it must be replaced.

d-d (mm)	Code	SP	Weight (kg)	Pieces
20 - 110	<b>790 132 061</b>	0	0.007	2



### IR-63 Plus Fusion Machine

#### Model:

- Fully-equipped manually operated infrared fusion machine with integrated remote welding unit
- Welding of PVDF SYGEF (Standard/Plus), ECTFE SYGEF, PP-H PROGEF (Standard/Plus), PP-n PROGEF Natural, PE100 ecoFIT, PFA
- Dimensions d20-63 mm
- Monochrome display with icons and various languages
- 2 USB interfaces
- Heating and facing element
- Clamping slide with movable clamping units
- Clamping inserts d20-63 mm (8 pcs. per dimension)
- End caps PE d20-63 mm (4 pcs. per dimension)
- Pipe stop
- Clean-room compatible accessory tray with tools
- Transport box
- 1-phase AC (50/60 Hz) 230V L/N/PE
- Power supply cable 230 V
- Extension cable for clamping slide, heater and facing tool for remote welding (5m each)
- Label printer
- Instruction manual

#### Note:

Clamping inserts PFA (inch) on request

d-d (mm)	Code	SP	Weight (kg)
20 - 63	<b>790 131 005</b>	1	50.000



### Clamping inserts

- The clamping inserts are different for each dimension. They are used to clamp and position the pipe components.

d (mm)	Code	SP	Weight (kg)	Pieces
20	<b>790 131 038</b>	1	0.140	1
25	<b>790 131 039</b>	1	0.090	1
32	<b>790 131 040</b>	1	0.052	1
40	<b>790 131 041</b>	1	0.074	1
50	<b>790 131 042</b>	1	0.100	1
63	<b>790 131 043</b>	1	0.035	1



### Set of facing knives

- A set includes two facing knives and six screws. Each facing knife has four blades. The blade may be turned three times before it must be replaced.

d-d (mm)	Code	SP	Weight (kg)	Pieces
20 - 63	<b>790 131 045</b>	1	0.016	2



### IR-110 Plus Fusion Machine

#### Model:

- Fully-equipped manually operated infrared fusion machine for use under clean room conditions
- Welding of PVDF SYGEF (Standard/Plus), ECTFE SYGEF, PP-H PROGEF (Standard/Plus), PP-n PROGEF Natural, PE100 ecoFIT, PFA
- Dimensions d20-110 mm
- Monochrome display with icons and various languages
- 2 USB interfaces
- Heating and facing element
- Clamping slide with movable clamping units
- Clamping inserts d20-90 mm (8 pcs. per dimension)
- End caps PE d20-110 mm (4 pcs. per dimension)
- Pipe stop
- Clean-room compatible accessory tray with tools
- Transport box with integrated pallet
- 1-phase AC (50/60 Hz) 230V L/N/PE
- Power supply cable 230V
- Label printer
- Instruction manual

#### Note:

Clamping inserts PFA (inch) on request

d-d (mm)	Code	Weight (kg)
20 - 110	<b>790 132 001</b>	75.000



### Clamping inserts

- The clamping inserts are different for each dimension. They are used to clamp and position the pipe components.

d (mm)	Code	SP	Weight (kg)	Pieces
20	<b>790 132 051</b>	0	0.108	1
25	<b>790 132 052</b>	0	0.106	1
32	<b>790 132 053</b>	0	0.104	1
40	<b>790 132 054</b>	0	0.100	1
50	<b>790 132 055</b>	0	0.095	1
63	<b>790 132 156</b>	0	0.085	1
75	<b>790 132 157</b>	0	0.087	1
90	<b>790 132 158</b>	0	0.064	1



### Set of facing knives

- A set includes two facing knives and six screws. Each facing knife has four blades. The blade may be turned three times before it must be replaced.

d-d (mm)	Code	SP	Weight (kg)	Pieces
20 - 110	<b>790 132 061</b>	0	0.007	2



### IR-225 Plus Fusion Machine

#### Model:

- Fully-equipped manually operated infrared fusion machine with integrated working table for use under clean room conditions
- Welding of PVDF SYGEF (Standard/Plus), ECTFE SYGEF, PP-H PROGEF (Standard/Plus), PP-n PROGEF Natural, PE100 ecoFIT
- Dimensions d63-225 mm
- Monochrome display with icons and various languages
- 2 USB interfaces
- Heating and facing element
- Clamping slide with movable clamping units
- Cooling fan
- Clamping inserts d63-225 mm (8 pcs. per dimension)
- End caps PE d63-225 mm (4 pcs. per dimension)
- Pipe stop
- Transport box with integrated pallet (stainless steel)
- 1-phase AC (50/60 Hz) 230V L/N/PE or 3-phase AC (50/60 Hz) 400V/230VL1/L2/L3/N/PE
- Connecting cable 400V - 230V
- Additional tools
- Label printer
- Instruction manual

d-d (mm)	Code	Weight (kg)
63 - 225	<b>790 133 009</b>	453.000



### Clamping inserts

- The clamping inserts are different for each dimension. They are used to clamp and position the pipe components.

d (mm)	Code	SP	Weight (kg)	Pieces
63	<b>790 133 026</b>	1	0.700	1
75	<b>790 133 027</b>	1	0.400	1
90	<b>790 133 028</b>	1	0.691	1
110	<b>790 133 029</b>	1	0.644	1
125	<b>790 133 030</b>	1	0.500	1
140	<b>790 133 031</b>	1	0.600	1
160	<b>790 133 032</b>	1	0.600	1
180	<b>790 133 463</b>	1	0.560	1
200	<b>790 133 033</b>	1	0.700	1
225	<b>790 133 034</b>	1	0.270	1



### Set of facing knives

- A set includes two facing knives and eight screws. Each facing knife has four blades. The blade may be turned three times before it must be replaced.

d-d (mm)	Code	SP	Weight (kg)	Pieces
63 - 225	<b>790 133 046</b>	1	0.125	2



### Set of end caps

- A set includes 4 end caps. The end caps are different for each dimension. The ends of the pipe **must** be closed. The caps prevent heat loss due to airflow in the fusion zone and guarantee optimum fusion results of the pipe components.

d (mm)	Code	SP	Weight (kg)	Pieces
20	<b>790 131 030</b>	4	0.040	4
25	<b>790 131 031</b>	4	0.010	4
32	<b>790 131 032</b>	4	0.088	4
40	<b>790 131 033</b>	4	0.005	4
50	<b>790 131 034</b>	4	0.005	4
63	<b>790 131 035</b>	4	0.023	4
75	<b>790 133 036</b>	4	0.095	4
90	<b>790 133 037</b>	4	0.028	4
110	<b>790 133 038</b>	4	0.180	4



### Label Printer

- Label 36 mm included, order Label 24 mm separately

description	Code	Weight (kg)
Label Printer Brother PT-P900W	<b>790 131 066</b>	2.740
Ribbon 24 mm Brother TZe-251	<b>790 131 065</b>	0.100



### Cleaning tissue KO-TON-R

Minimum order quantity 100 pieces

- This cleaning tissue is suitable for the cleaning of the welding zone of piping components, because it is lint free and clean room checked.

Code	Weight (kg)
<b>790 122 085</b>	0.005



### Tangit KS Cleaner

- Special cleaner for plastic fusion connections in the material of PP, PE, PVDF and PB
- Suitable for Tangit Rapid. Must not be used for solvent cementing
- DVGW approved
- DW 5290 BR 0464

Size	Code	SP	Weight (kg)
1 liter	<b>799 298 023</b>	8	0.872





# Worldwide at home

Our sales companies and representatives ensure local customer support in more than 100 countries.

[www.gfps.com](http://www.gfps.com)

## Argentina / Southern South America

Georg Fischer Central Plastics Sudamérica S.R.L.  
Buenos Aires / Argentina  
Phone +54 11 4512 02 90  
gfcentral.ps.ar@georgfischer.com  
www.gfps.com/ar

## Australia

Georg Fischer Pty Ltd  
Riverwood NSW 2210  
Phone +61 (0) 2 9502 8000  
australia.ps@georgfischer.com  
www.gfps.com/au

## Austria

Georg Fischer Rohrleitungssysteme GmbH  
3130 Herzogenburg  
Phone +43 (0) 2782 856 43-0  
austria.ps@georgfischer.com  
www.gfps.com/at

## Belgium / Luxembourg

Georg Fischer NV/SA  
1600 Sint-Pieters-Leeuw / Belgium  
Phone +32 (0) 2 556 40 20  
Fax +32 (0) 2 524 34 26  
be.ps@georgfischer.com  
www.gfps.com/be

## Brazil

Georg Fischer Sist. de Tub. Ltda.  
04571-020 São Paulo/SP  
Phone +55 (0) 11 5525 1311  
br.ps@georgfischer.com  
www.gfps.com/br

## Canada

Georg Fischer Piping Systems Ltd  
Mississauga, ON L5T 2B2  
Phone +1 (905) 670 8005  
Fax +1 (905) 670 8513  
ca.ps@georgfischer.com  
www.gfps.com/ca

## China

Georg Fischer Piping Systems Ltd  
Shanghai 201319  
Phone +86 21 3899 3899  
china.ps@georgfischer.com  
www.gfps.com/cn

## Denmark / Iceland

Georg Fischer A/S  
2630 Taastrup / Denmark  
Phone +45 (0) 70 22 19 75  
info.dk.ps@georgfischer.com  
www.gfps.com/dk

## Finland

Georg Fischer AB  
01510 Vantaa  
Phone +358 (0) 9 586 58 25  
Fax +358 (0) 9 586 58 29  
info.fi.ps@georgfischer.com  
www.gfps.com/fi

## France

Georg Fischer SAS  
95932 Roissy Charles de Gaulle Cedex  
Phone +33 (0) 1 41 84 68 84  
fr.ps@georgfischer.com  
www.gfps.com/fr

## Germany

Georg Fischer GmbH  
73095 Albershausen  
Phone +49 (0) 7161 302 0  
info.de.ps@georgfischer.com  
www.gfps.com/de

## India

Georg Fischer Piping Systems Pvt. Ltd  
400 083 Mumbai  
Phone +91 22 4007 2000  
Fax +91 22 4007 2020  
branchoffice@georgfischer.com  
www.gfps.com/in

## Indonesia

PT Georg Fischer Indonesia  
Karawang 41371, Jawa Barat  
Phone +62 267 432 044  
Fax +62 267 431 857  
indonesia.ps@georgfischer.com  
www.gfps.com/id

## Italy

Georg Fischer S.p.A.  
20864 Agrate Brianza (MB)  
Phone +39 02 921 86 1  
Fax +39 02 921 86 24 7  
it.ps@georgfischer.com  
www.gfps.com/it

## Japan

Georg Fischer Ltd  
530-0003 Osaka  
Phone +81 (0) 6 6341 2451  
jp.ps@georgfischer.com  
www.gfps.com/jp

## Korea

Georg Fischer Korea Co. Ltd  
Unit 2501, U-Tower  
120 Heungdeok Jungang-ro  
(Yeongdeok-dong)  
Giheung-gu, Yongin-si, Gyeonggi-do  
Phone +82 31 8017 1450  
Fax +82 31 217 1454  
kor.ps@georgfischer.com  
www.gfps.com/kr

## Malaysia

Georg Fischer (M) Sdn. Bhd.  
41200 Klang, Selangor Darul Ehsan  
Phone +60 (0) 3 3122 5585  
Fax +60 (0) 3 3122 5575  
my.ps@georgfischer.com  
www.gfps.com/my

## Mexico / Northern Latin America

Georg Fischer S.A. de C.V.  
CP 66636 Apodaca, Nuevo Leon / Mexico  
Phone +52 (81) 1340 8586  
Fax +52 (81) 1522 8906  
mx.ps@georgfischer.com  
www.gfps.com/mx

## Middle East

Georg Fischer Piping Systems (Switzerland) Ltd  
Dubai / United Arab Emirates  
Phone +971 4 289 49 60  
gcc.ps@georgfischer.com  
www.gfps.com/int

## Netherlands

Georg Fischer N.V.  
8161 PA Epe  
Phone +31 (0) 578 678 222  
nl.ps@georgfischer.com  
www.gfps.com/nl

## New Zealand

Georg Fischer Ltd  
5018 Upper Hutt  
Phone +04 527 9813  
Fax +04 527 9834  
nz.ps@georgfischer.com  
www.gfps.com/nz

## Norway

Georg Fischer AS  
1351 Rud  
Phone +47 67 18 29 00  
no.ps@georgfischer.com  
www.gfps.com/no

## Philippines

George Fischer Pte. Ltd.  
Philippines Representative Office  
1500 San Juan City  
Phone +632 571 2365  
Fax +632 571 2368  
sgp.ps@georgfischer.com  
www.gfps.com/sg

## Poland

Georg Fischer Sp. z o.o.  
05-090 Sekocin Nowy  
Phone +48 (0) 22 31 31 0 50  
poland.ps@georgfischer.com  
www.gfps.com/pl

## Romania

Georg Fischer Piping Systems (Switzerland) Ltd  
020257 Bucharest - Sector 2  
Phone +40 (0) 21 230 53 80  
ro.ps@georgfischer.com  
www.gfps.com/int

## Russia

Georg Fischer Piping Systems (Switzerland) Ltd  
Moscow 125040  
Phone +7 495 748 11 44  
ru.ps@georgfischer.com  
www.gfps.com/ru

## Singapore

Georg Fischer Pte Ltd  
528 872 Singapore  
Phone +65 6747 0611  
Fax +65 6747 0577  
sgp.ps@georgfischer.com  
www.gfps.com/sg

## Spain / Portugal

Georg Fischer S.A.  
28046 Madrid / Spain  
Phone +34 (0) 91 781 98 90  
es.ps@georgfischer.com  
www.gfps.com/es

## Sweden

Georg Fischer AB  
117 43 Stockholm  
Phone +46 (0) 8 506 775 00  
info.se.ps@georgfischer.com  
www.gfps.com/se

## Switzerland

Georg Fischer Rohrleitungssysteme (Schweiz) AG  
8201 Schaffhausen  
Phone +41 (0) 52 631 3026  
ch.ps@georgfischer.com  
www.gfps.com/ch

## Taiwan

Georg Fischer Co. Ltd  
San Chung Dist., New Taipei City  
Phone +886 2 8512 2822  
Fax +886 2 8512 2823  
www.gfps.com/tw

## United Kingdom / Ireland

George Fischer Sales Limited  
Coventry, CV2 2ST / United Kingdom  
Phone +44 (0) 2476 535 535  
uk.ps@georgfischer.com  
www.gfps.com/uk

## USA / Caribbean

Georg Fischer LLC  
92618 Irvine, CA / USA  
Phone +1 714 731 8800  
Fax +1 714 731 6201  
us.ps@georgfischer.com  
www.gfps.com/us

## Vietnam

Georg Fischer Pte Ltd  
Representative Office  
Ho Chi Minh City  
Phone +84 28 3948 4000  
Fax +84 28 3948 4010  
sgp.ps@georgfischer.com  
www.gfps.com/vn

## International

Georg Fischer Piping Systems (Switzerland) Ltd  
8201 Schaffhausen / Switzerland  
Phone +41 (0) 52 631 3003  
Fax +41 (0) 52 631 2893  
info.export@georgfischer.com  
www.gfps.com/int

The information and technical data (altogether "Data") herein are not binding, unless explicitly confirmed in writing. The Data neither constitutes any expressed, implied or warranted characteristics, nor guaranteed properties or a guaranteed durability. All Data is subject to modification. The General Terms and Conditions of Sale of Georg Fischer Piping Systems apply.



700.671.691

GFDO\_BR\_00030a\_EN (02.20)

© Georg Fischer Piping Systems Ltd  
8201 Schaffhausen/Switzerland, 2020



Pobrano ze strony:  
[gambitsystems.pl](http://gambitsystems.pl)

